

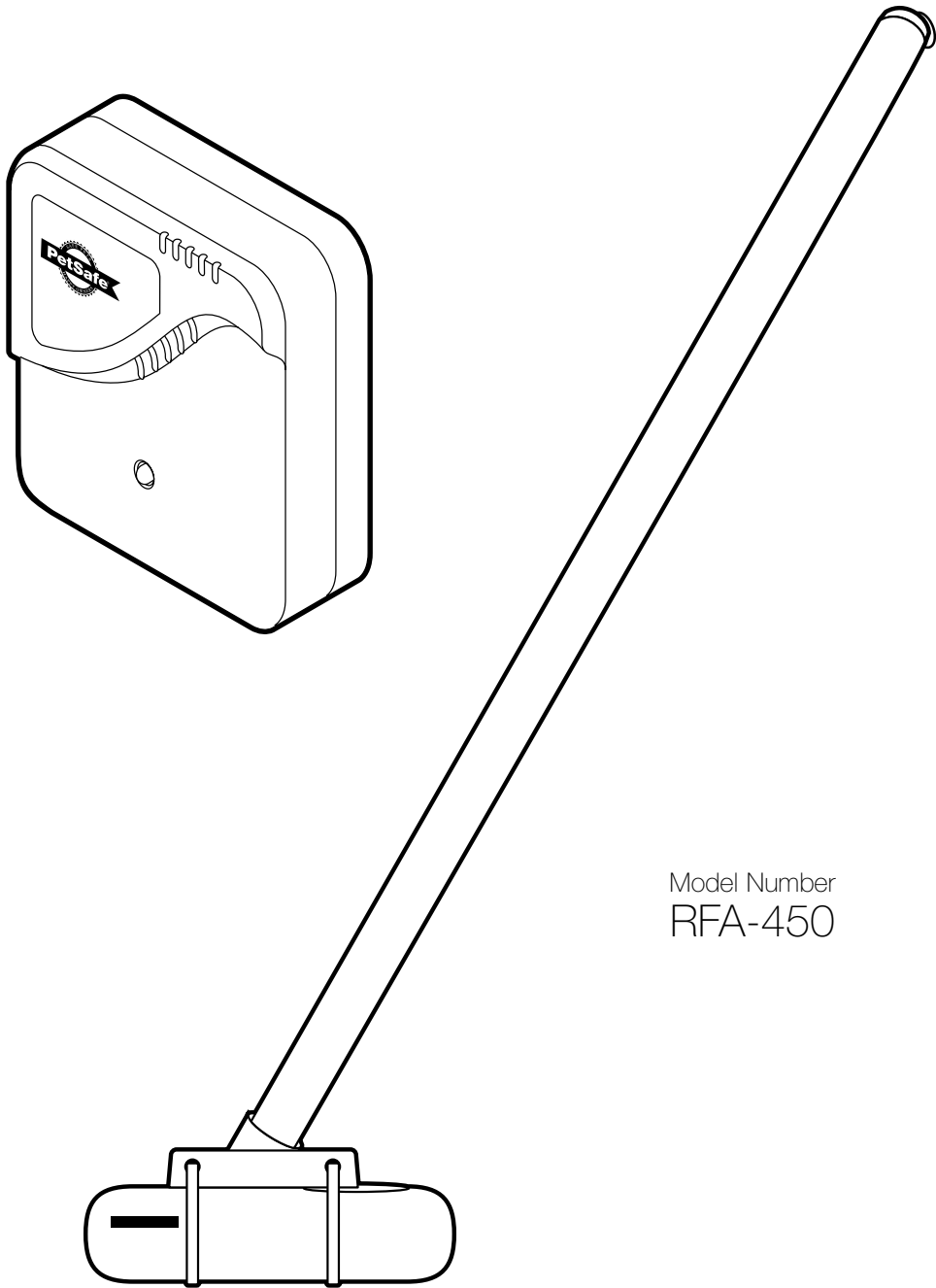

protect. **teach.** love.™



Model Number  
RFA-450

# wire break locator

## operating guide

PLEASE READ THIS ENTIRE GUIDE BEFORE BEGINNING

# Important Safety Information

## Explanation of Attention Words and Symbols used in this guide



This is the safety alert symbol. It is used to alert you to potential personal injury hazards. Obey all safety messages that follow this symbol to avoid possible injury or death.

### **⚠ WARNING**

WARNING indicates a hazardous situation which, if not avoided, could result in death or serious injury.

### **⚠ CAUTION**

CAUTION, used with the safety alert symbol, indicates a hazardous situation which, if not avoided, could result in minor or moderate injury.

### **NOTICE**

NOTICE is used to address safe use practices not related to personal injury.

---

### **⚠ WARNING**

- Underground cables can carry high voltage. Have all underground cables marked before you dig to repair or bury your wire. In most areas this is a free service. Avoid these cables when you dig.
- Follow all safety instructions for your power tools. Be sure to always wear your safety goggles.
- Do not install, connect, or remove your system during a lightning storm. If the storm is close enough for you to hear thunder, it is close enough to create hazardous surges.
- Risk of electric shock. Use the Fence Transmitter indoors in dry location only.
- Choking Hazard — Small objects such as the tie wrap represent a choking hazard to children and pets. Do not allow children or pets access to these items.

### **⚠ CAUTION**

- Risk of injury. Wire on top of the ground may be a trip hazard; Use care in how you place your wires.
- Watch where you're walking. Stakes driven into the ground can create obstacles that could cause you to trip.
- Laceration possible from sharp edges if the telescoping handle becomes broken.

### **NOTICE**

- Connect power to the Wire Break Location Transmitter using supplied 12V adapter. Damage to the Transmitter will occur if improper adapter is used.

Thank you for choosing PetSafe® brand. You and your pet deserve a companionship that includes memorable moments and a shared understanding together. Our products provide you with the tools and technologies to successfully train your pet. If you have any questions about our products or training your pet, please visit our website at [www.petsafe.net](http://www.petsafe.net) or contact our Customer Care Center at 1-800-732-2677.

To get the most protection out of your warranty, please register your product within 30 days at [www.petsafe.net](http://www.petsafe.net). By registering and keeping your receipt, you will enjoy the product's full warranty and should you ever need to call the Customer Care Center, we will be able to help you faster. Most importantly, we will never give or sell your valuable information to anyone.

Complete warranty information is available online at [www.petsafe.net](http://www.petsafe.net).

## Components

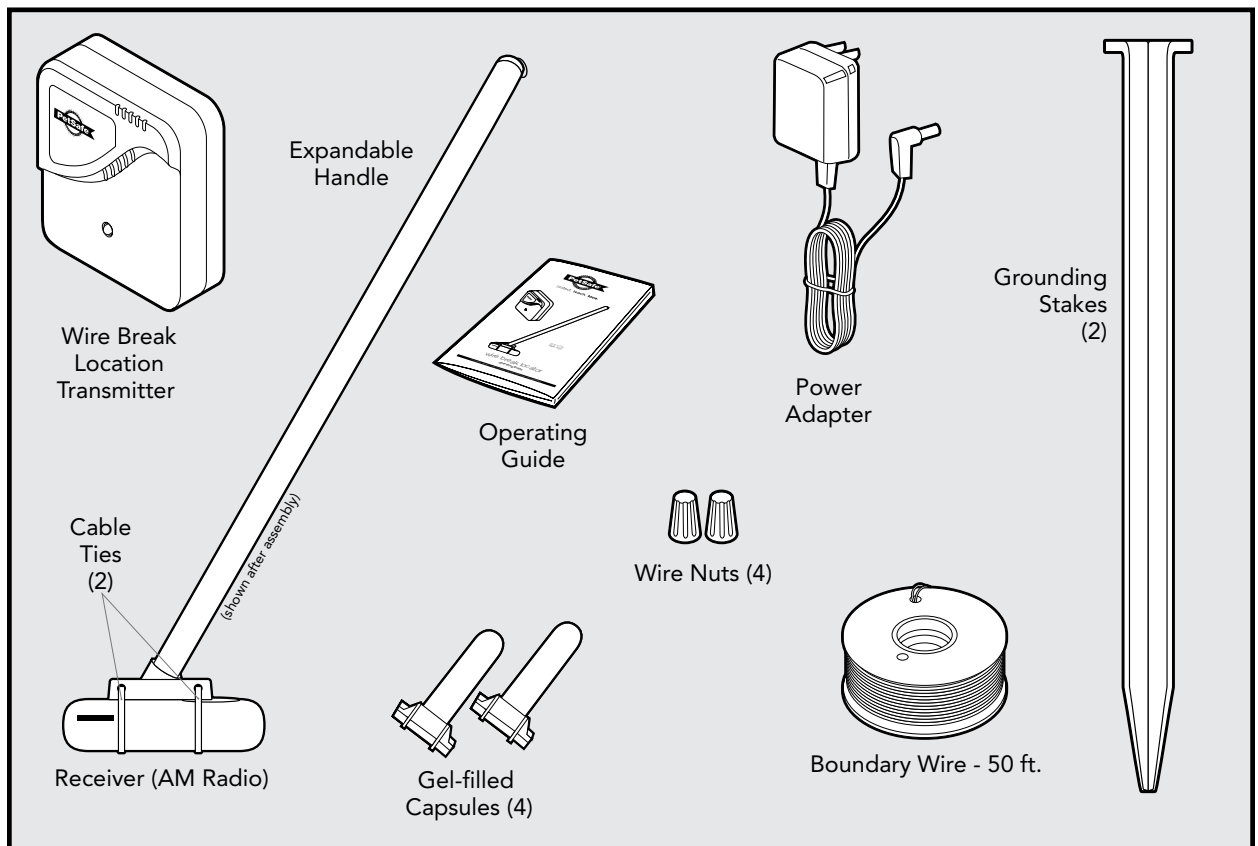

## Required Components (Not Included in Kit)

- (2) AAA Batteries for Receiver (AM radio)

## Other Items You May Need

- Additional Boundary Wire (Part #RFA-1)
- Tape measure
- Shovel or lawn edger
- Additional Gel-filled Capsules and Wire Nuts (Part # RFA-366)
- Pliers
- Wire stripping pliers
- Hammer

Wire Break Locator Video: [www.petsafe.net](http://www.petsafe.net)

# How it works

The Wire Break Locator is designed to find complete breaks in your Boundary Wire. It is not designed to detect partial wire breaks. The Transmitter outputs a separate unique signal on each of the Boundary Wires connected to the Wire Break Locator Transmitter. A continuous low frequency tone is transmitted on one Boundary Wire and an intermittent higher tone is transmitted on the other Boundary Wire. The Receiver is used to pick up these tones and to detect a noticeable change. When a receiver is over a wire break, a continuous tone may change to an intermittent tone or an intermittent tone may change to a continuous tone. Most conditions will show a decrease in volume over the break.

---

## Indicators to use the Wire Break Locator

There is a wire break indication on the containment Transmitter.

The Receiver Collar is not functioning on the containment system, but operates during the System Test.

---

## Additional Information

Wire breaks in the twisted pair are commonly found:

- a. At the wire exit point of the house
- b. Where the twisted pair of wire enters the ground from the house, usually caused by string trimmers
- c. Where the wires cross sidewalks or driveways due to edging and string trimmers
- d. Around landscaping and flower beds due to digging, or working up the soil

Wire breaks in the Boundary Wire are commonly found:

- a. In aerated lawns
  - b. Where the wires cross sidewalks or driveways due to edging and string trimmers
  - c. Around landscaping and flower beds due to digging, or working up the soil
  - d. At wire splices where Gel-filled capsules have not been installed
  - e. At wire splices without reinforcement knots (refer to **Figure 9**)
- 

## Before you begin

For proper electrical grounding, the earth must be wet. Several gallons of water may need to be poured around the grounding stakes to moisten dry earth.

It is acceptable to repair solid Boundary Wire with stranded Boundary Wire or to repair stranded Boundary Wire with solid Boundary Wire, but the same gauge such as 20 gauge wire must be used with both types of wire.

Aerated lawns may require long lengths of wire to be replaced as opposed to small sections. Aerated lawns can cut the wire into small sections; therefore, instead of making small section repairs, it may be easier to replace a long length of wire.

# Setting up the Wire Break Locator Transmitter

1. Turn the existing containment Transmitter off. Disconnect the Boundary Wires from the Transmitter and unplug the AC power adapter from the Transmitter.
2. Connect the 2 Boundary Wires to the two **RED LOOP** wire connectors on the Wire Break Locator Transmitter
3. For proper operation of the Transmitter, two separate grounding wires must be connected to the **BLACK GROUND** terminals of the Wire Break Locator Transmitter. Using the spool of wire supplied in the kit, Strip  $\frac{3}{8}$ " of insulation off of the wire on one end of the spool. Insert the stripped end of the spool into one of the GROUND terminals on the Wire Break Locator Transmitter as shown in **Figure 1**.

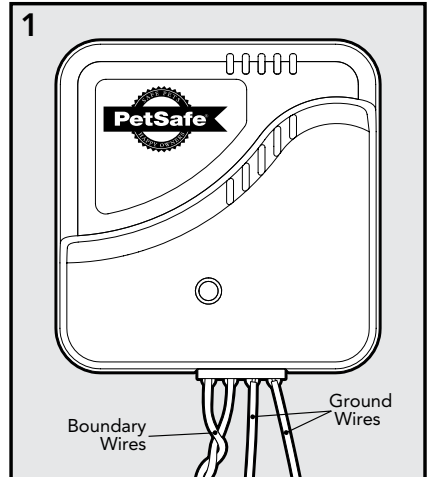

*NOTE: Each ground connection on the Transmitter must be connected to a separate grounding stake supplied in the RFA-450 kit. These grounding stakes must be inserted into the earth outside of the home/garage for the transmitted signal to operate properly. These stakes should be 2-3 feet apart.*

4. Slip the small wire spool through your finger and unroll the wire by allowing the spool to rotate on your finger as you walk away from the Wire Break Locator Transmitter. Walk to an outside area where there is a small section of ground available to insert the grounding stakes. Note: It is recommended to keep these ground connection wires as short as possible by trimming off any excess wire between the Wire Break Locator Transmitter and the intended location of the grounding stakes. Cut the wire and strip 2 inches of insulation off of the wire to connect to the grounding stake. Place the wire through the small hole in the grounding stake and tightly twist the wire as shown in **Figure 2**. Make sure that the wire is tightly wrapped around the stake and that the copper is making good connection with the metal on the grounding stake as shown in **Figure 3**. Repeat Steps 3 and 4 to connect the other wire to the second Transmitter ground terminal and grounding stake.

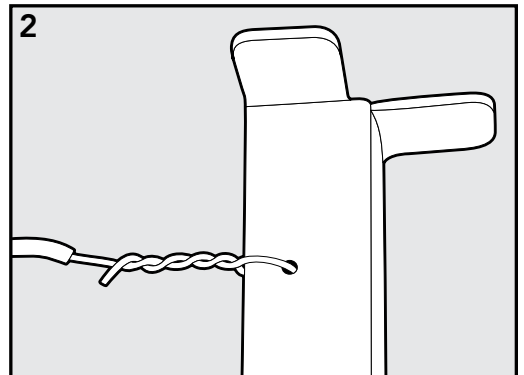

5. The grounding stakes should be located at least 2-3 feet apart in the ground. Insert the grounding stakes into the ground about 8 inches with about 2 inches remaining from the end. After the grounding stakes are installed, make sure that the wire is tightly wrapped around the stake and that the copper is making good connection with the metal on the grounding stake as shown in **Figure 3**.

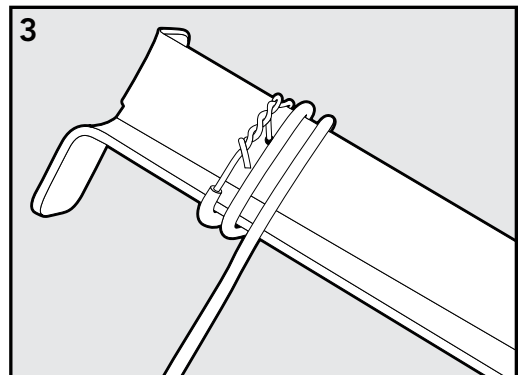

6. Recheck the LOOP and GROUND wire connections at the Wire Break Location Transmitter and verify that they are securely installed.
7. Plug the Power Adapter supplied in the RFA-450 kit into the Power Jack and AC Power Outlet. The green Power Light will flash quickly indicating power is supplied.

# Setting up the Wire Break Locator Receiver

1. Install two AAA Alkaline batteries (not included) in the Receiver.
2. Attach the Receiver to the mounting fixture on the end of the expandable handle using the two enclosed cable ties as shown in **Figure 4**. The Receiver speaker should be located at the back side of the fixture.  
*Important: Do not over-tighten the cable ties as this can make using the Receiver controls difficult to operate.*
3. Turn the Receiver on and adjust the tuning dial to the lower end of the tuning band (below 620kHz when possible). Adjust the tuning dial to a location where no radio stations are broadcasting and the output of the Receiver is producing a static noise.

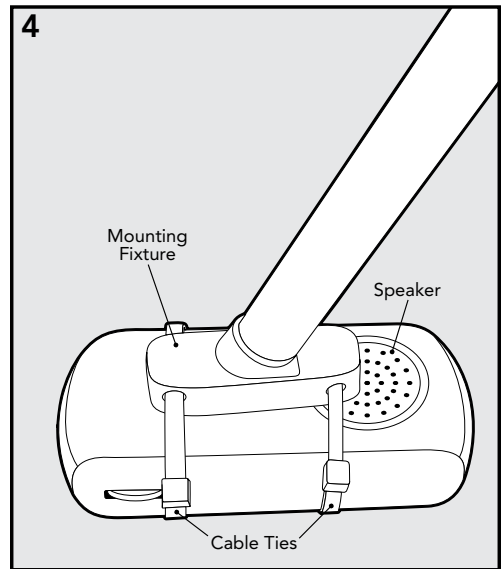

## Becoming familiar with the system

The Transmitter outputs a separate unique signal on each of the Boundary Wires connected to the Wire Break Locator Transmitter. A continuous low frequency tone is transmitted on one of the Boundary wires and an intermittent higher tone is transmitted on the other Boundary Wire. The Receiver is used to pick up these tones.

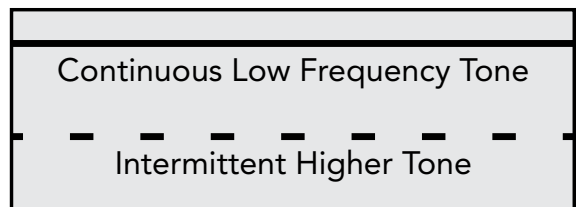

To become familiar with the sound of the two tones, place the Receiver over one and then the other of the ground wires connecting the Wire Break Location Transmitter to the grounding stakes. Be sure to separate the wires by several feet to prevent both signals from being picked up together. To understand what the mixed signals sound like, place the Receiver over the twisted wires connected to the Loop Terminals of the Wire Break Location Transmitter. Adjust the Receiver volume so the signals are loud enough to easily hear the tones over normal ambient outdoor noise.

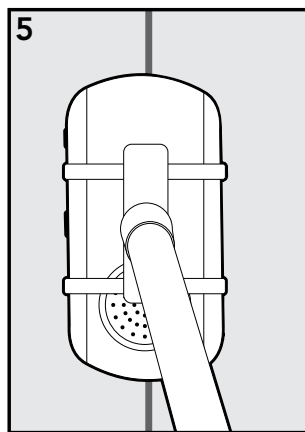

**For proper signal reception, Receiver must be parallel to Boundary Wire.**

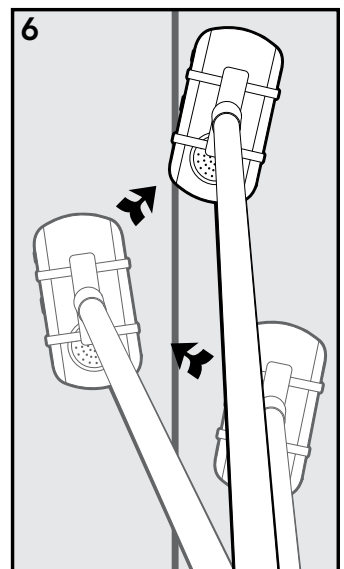

Visit [www.petsafe.net](http://www.petsafe.net) to view the Wire Break Location video. You will see a product demonstration and hear how the tones differ.

While trying to locate the break, make sure to follow the path of the wire (**Figure 5**). In order to follow the path, swing the unit from side to side and continue in the direction of the greatest sound volume (**Figure 6**). Maximum sound volume is achieved when the Receiver is placed directly over the Boundary Wire. As you near a break or pass over a break, the volume will decrease and/or it will change from one tone to the other. This will depend upon whether there are multiple breaks.

For a single break, the tone will change from one to another (intermittent to continuous or continuous to intermittent). There will be a decrease in sound volume over the break.

If there are multiple breaks, the sound volume will decrease and disappear at the break.

# Finding the Wire Break

Begin where the twisted pair of wire exits your home (through a window, door, or wall) using the Receiver.

The two transmitted signals mix over the twisted pair going from the Transmitter to the boundary loop. As a result you will hear both the low frequency continuous tone and the higher frequency intermittent tone together.

If both wires are damaged in the twisted pair, the signal from the Receiver will decrease as you near the break and quit after you have passed the break.

If only a single wire is broken you will hear both tones as you follow the twisted wire away from the transmitter. At the point where the single wire is broken, only a single tone will be heard.

If you have not located a break(s) in the twisted pair of wires, you will eventually get to the Boundary Wire connection point.

When you get to the end of the twisted pair at the boundary loop, the signals will separate again and you will hear one signal as you follow the boundary wire in one direction, and you will hear the other signal as you follow the boundary wire in the other direction.

*Note: If the twisted pair is greater than 100 feet, an intermittent and steady tone will most likely be combined over the entire Boundary Wire. If this occurs, you will hear a noticeable reduction in sound volume over the break.*

Choose a boundary direction and continue walking along the Boundary Wire. When you come to a break in the Boundary Wire, there will be either no signal or the signal will cross over from intermittent to continuous or continuous to intermittent. Once you've identified the general location of the wire break, move the Receiver 2-3 feet from the break. Turn the volume down on the Receiver until you only hear the sound when you are directly over the wire. Move the Receiver towards the wire break. When the sound disappears, you have located the break. The break should be directly below the Receiver.

As you move further from the Transmitter, the Receiver volume will gradually decrease. This is not to be confused with a wire break.

If the twisted pair is greater than 50 feet and there are keep-out areas such as gardens and pools in your Boundary layout, you may need to locate the break by listening for a reduction in the sound volume.

If there are multiple breaks, keep repairing as you go around. If the lawn was aerated, replacing a larger section of wire may be easier than making small section repairs. Go back to the twisted pair and walk the Boundary Wire in the other direction until the signal disappears for that break. Replace the wire between the two ends of the Boundary Wire breaks.

# Repair the Wire Break

When you have found the location of the wire break, you will need to dig the wire ends out of the ground to make the repairs.

Be certain to dig with the shovel blade parallel to the wire. Begin digging 4-5 inches to the side of the wire. Otherwise you could damage the wire (**Figure 7**).

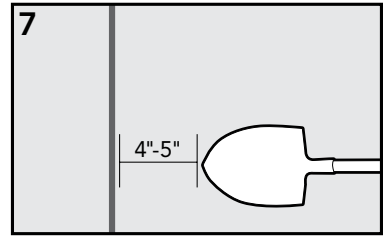

Strip approximately  $\frac{3}{8}$  inch of insulation off the ends of the Boundary Wires to be spliced (**Figure 8**). Make sure the copper Boundary Wire is not corroded. If the Boundary Wire is corroded, cut it back to expose clean copper wire.

Insert the stripped ends into the wire nut and twist the wire nut around the wires. Ensure that there is no copper exposed beyond the end of the wire nut. Tie a knot 3 to 4 inches from the wire nut (**Figure 9**). Ensure that the wire nut is secure on the wire splice.

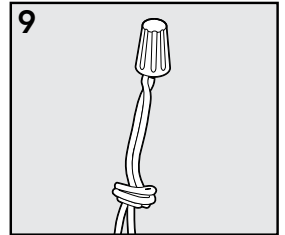
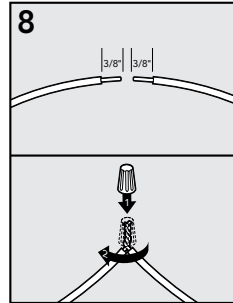

Once you have securely spliced the wires together, open the lid of the gel-filled splice capsule and insert the wire nut as deeply as possible into the waterproof gel inside the capsule (**Figure 10**). Snap the lid of the capsule shut (**Figure 11**). For proper system performance, the splice connection must be waterproof.

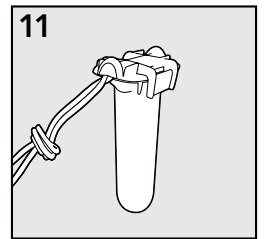
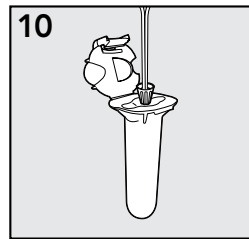

If your splice pulls loose, the entire system will fail. Make sure your splice is secure. Additional gel-filled splice capsules and wire nuts are available through the Customer Care Center.

Make sure to have enough wire to repair the break. You will need a length of wire at least 2 feet longer than the distance between the two ends of the exposed clean copper wire (**Figure 12**).

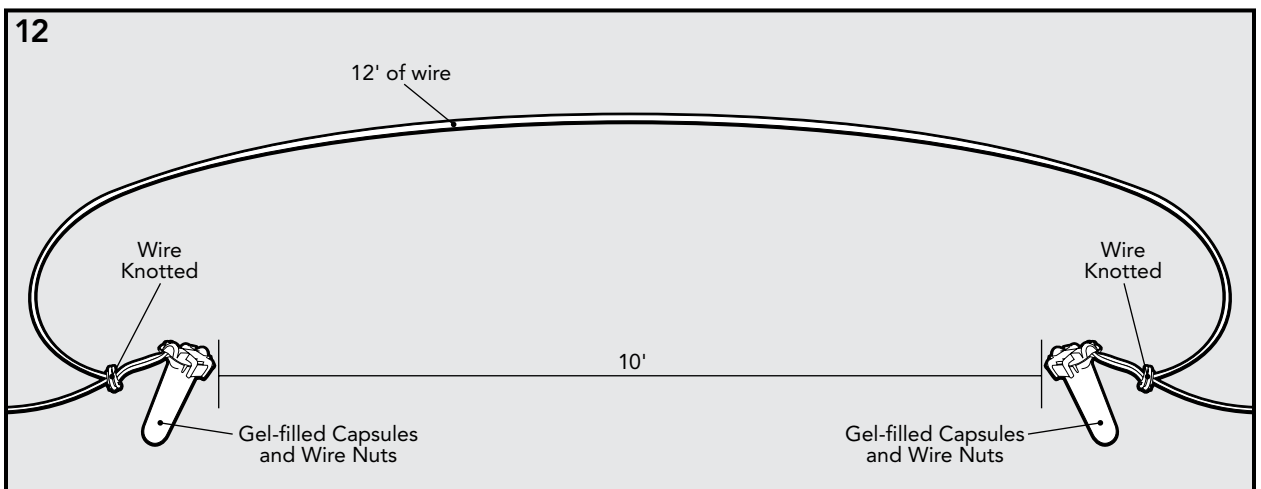

After you have repaired the wire break, take the Receiver and continue walking around the boundary to verify there are no more wire breaks. If there are no more wire breaks, you will hear intermittent and continuous tones all the way around the boundary.

Connect your Fence Transmitter to the Boundary Wire and check that the loop light is lit. If the loop light is not lit, there may be another break in the wire. Verify that your system is working with the Receiver Collar. Verify that the Boundary Width for the Warning Zone is approximately 12-20 feet (6 to 10 feet on each side of the wire) before placing the Receiver Collar on your pet.



# Terms of Use and Limitation of Liability

## 1. Terms of Use

This Product is offered to you conditioned upon your acceptance without modification of the terms, conditions and notices contained herein. Usage of this Product implies acceptance of all such terms, conditions, and notices.

## 2. No Unlawful or Prohibited Use

Using this Product in a way that is not intended could result in violation of Federal, State or local laws.

## 3. Limitation of Liability

In no event shall Radio Systems® Corporation be liable for any direct, indirect, punitive, incidental, special or consequential damages, or any damages whatsoever arising out of or connected with the use or misuse of this Product. Buyer assumes all risks and liability from the use of this Product.

## 4. Modification of Terms and Conditions

Radio Systems® Corporation reserves the right to change the terms, conditions and notices under which this Product is offered.

---

# Compliance

## FCC/Canada

This device complies with FCC rules CFR 47 Part 15.103(c) and ICES-003 1.2.2(d). This device is for use only to locate and correct a wire break. It shall not be used beyond the time needed to find the loop break for repair. Use of this device in any other way may violate FCC rules.





Radio Systems® Corporation  
10427 PetSafe Way  
Knoxville, TN 37932  
1-800-732-2677  
[www.petsafe.net](http://www.petsafe.net)

Protected by US Patent 6,215,314. Other patent pending.

400-1208/3

©2014 Radio Systems Corporation